

DRONACHARYA College of Engineering

Computer Science & Engineering

Data Communication and Computer Networks

(MTCSE-101-A)

Network Layer Example

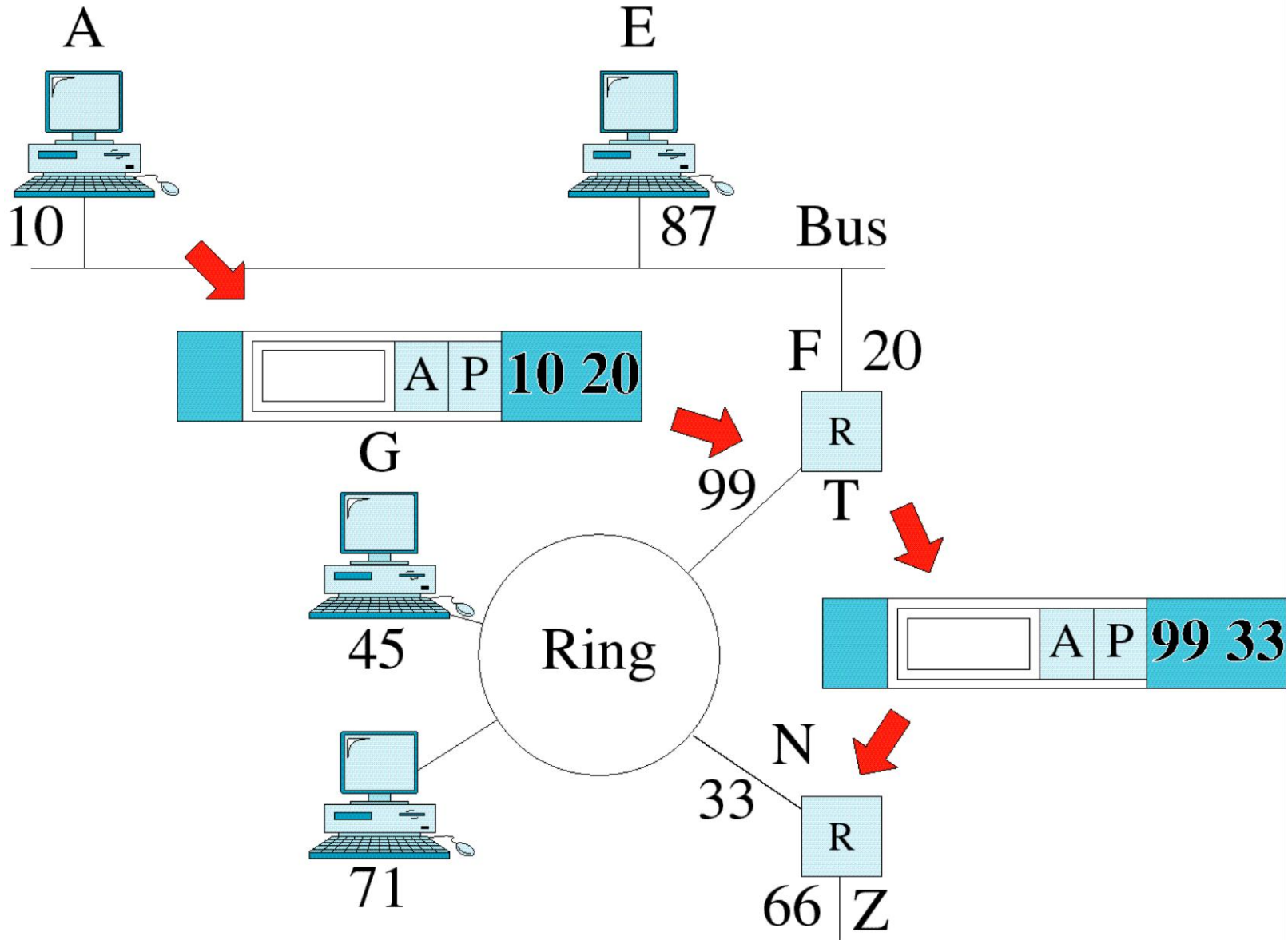

Network Layer Example

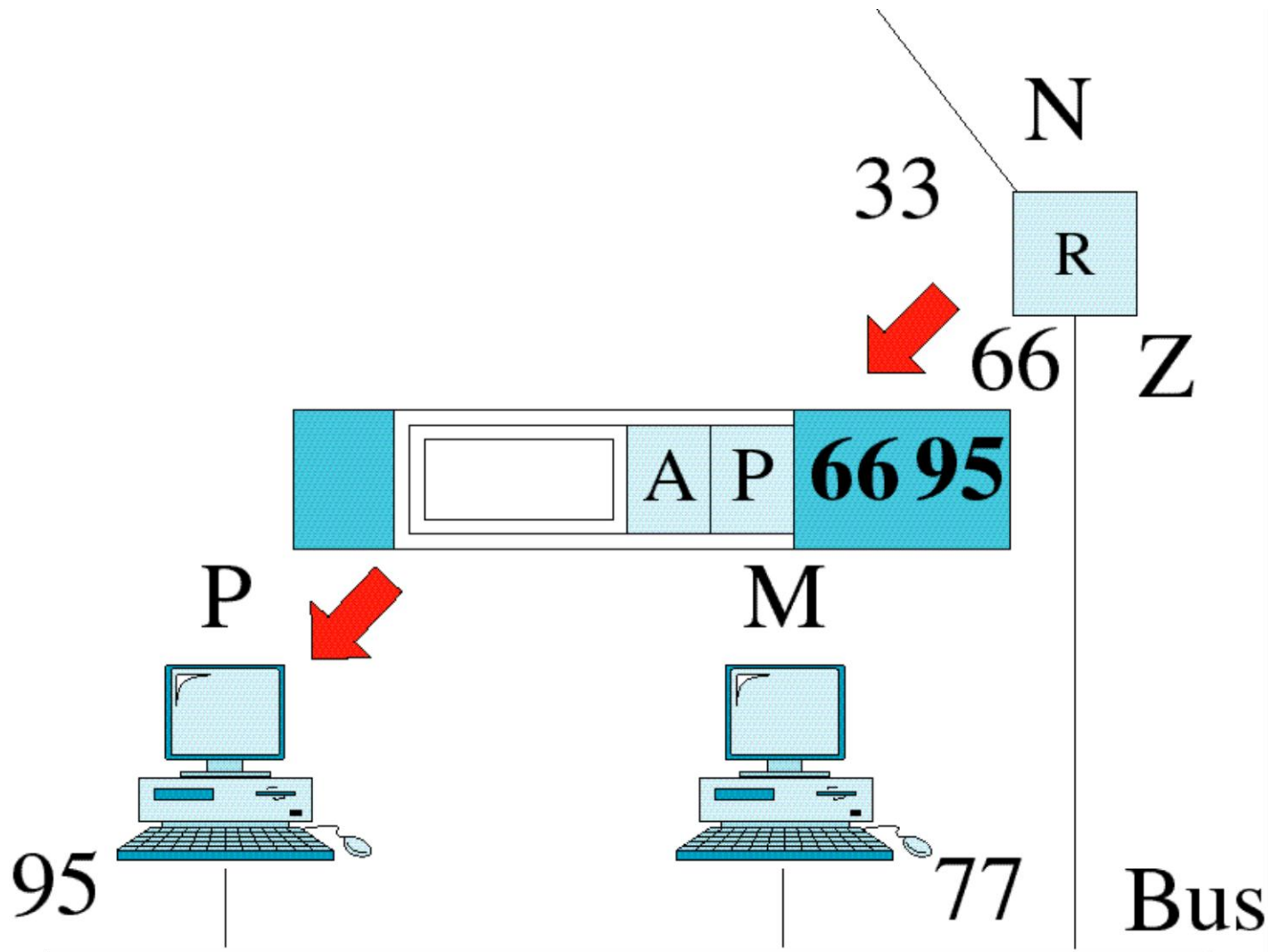

Transport Layer

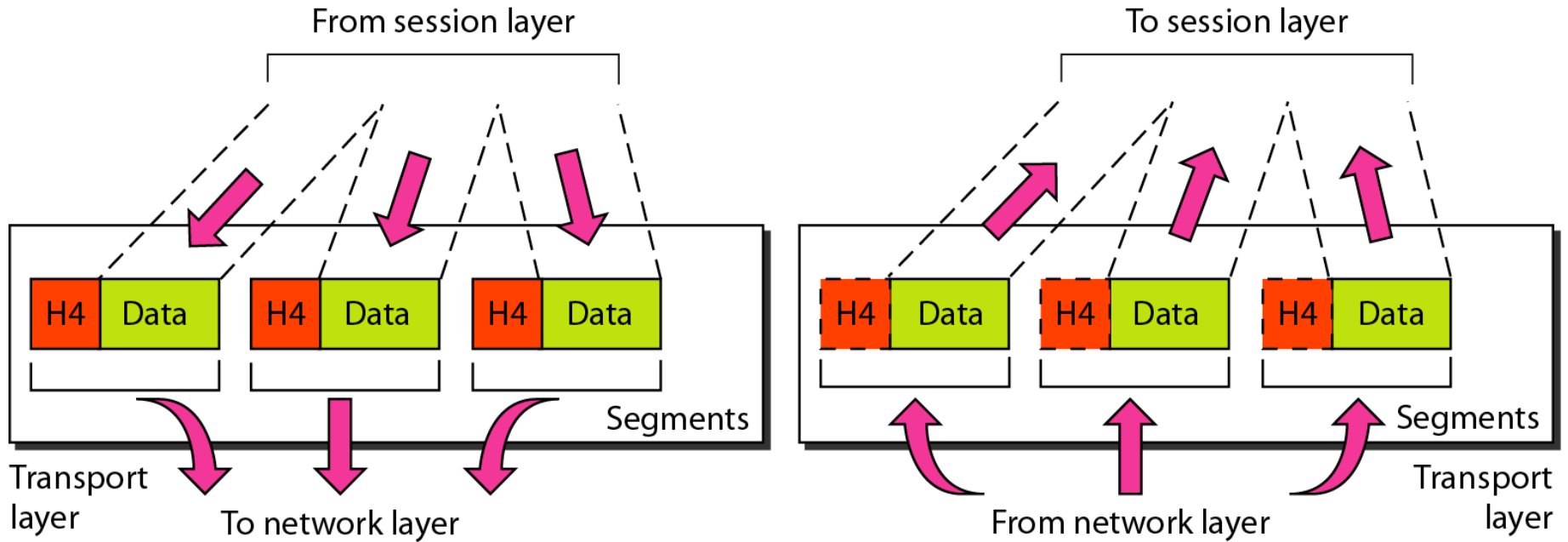

The transport layer is responsible for the delivery of a message from one process to another.

Reliable process-to-process delivery of a message

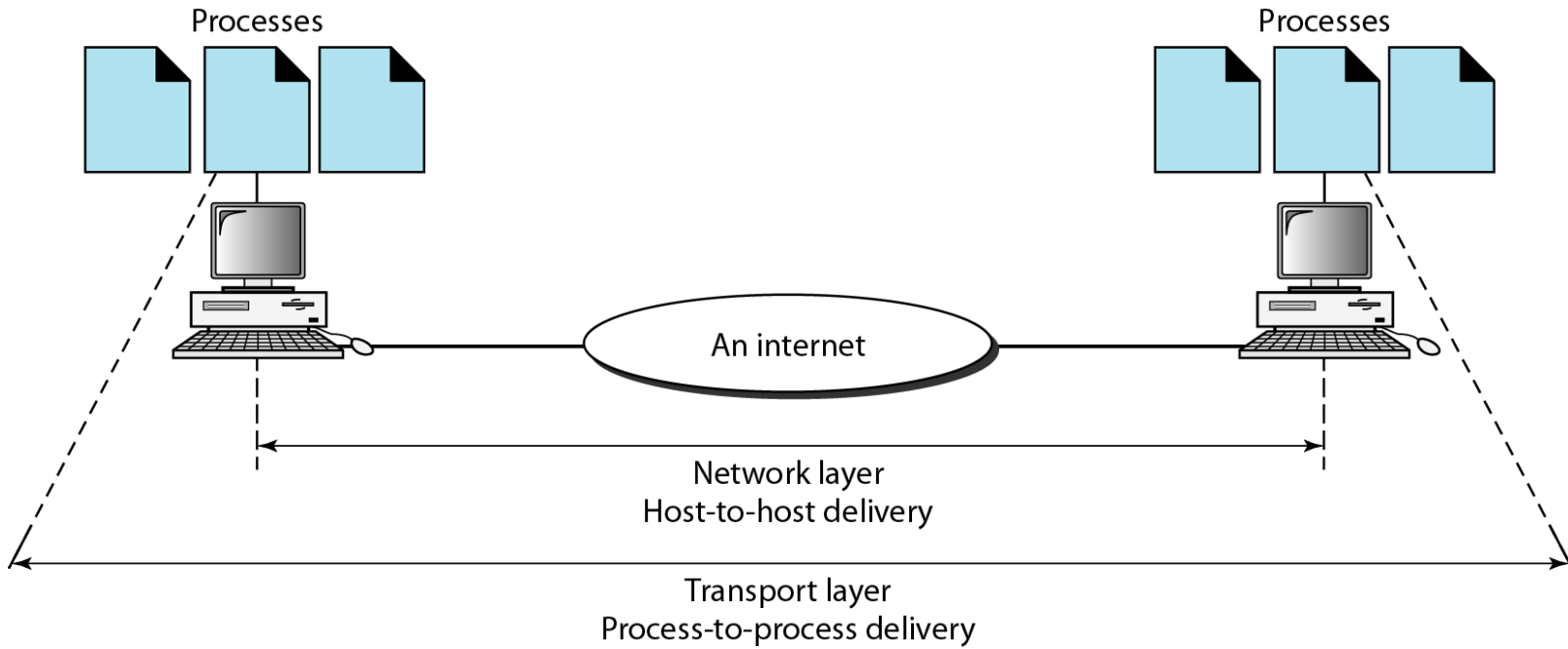

Transport Layer

Responsibility of transport layer

- ❑ Purpose of this layer is to provide a reliable mechanism for the exchange of data between two processes in different computers.
- ❑ Segmentation and Reassembly
- ❑ Ensures that the data units are delivered error free.
- ❑ Ensures that data units are delivered in sequence.
- ❑ Ensures that there is no loss or duplication of data units.
- ❑ Provides connectionless or connection oriented service.

Transport Layer Example

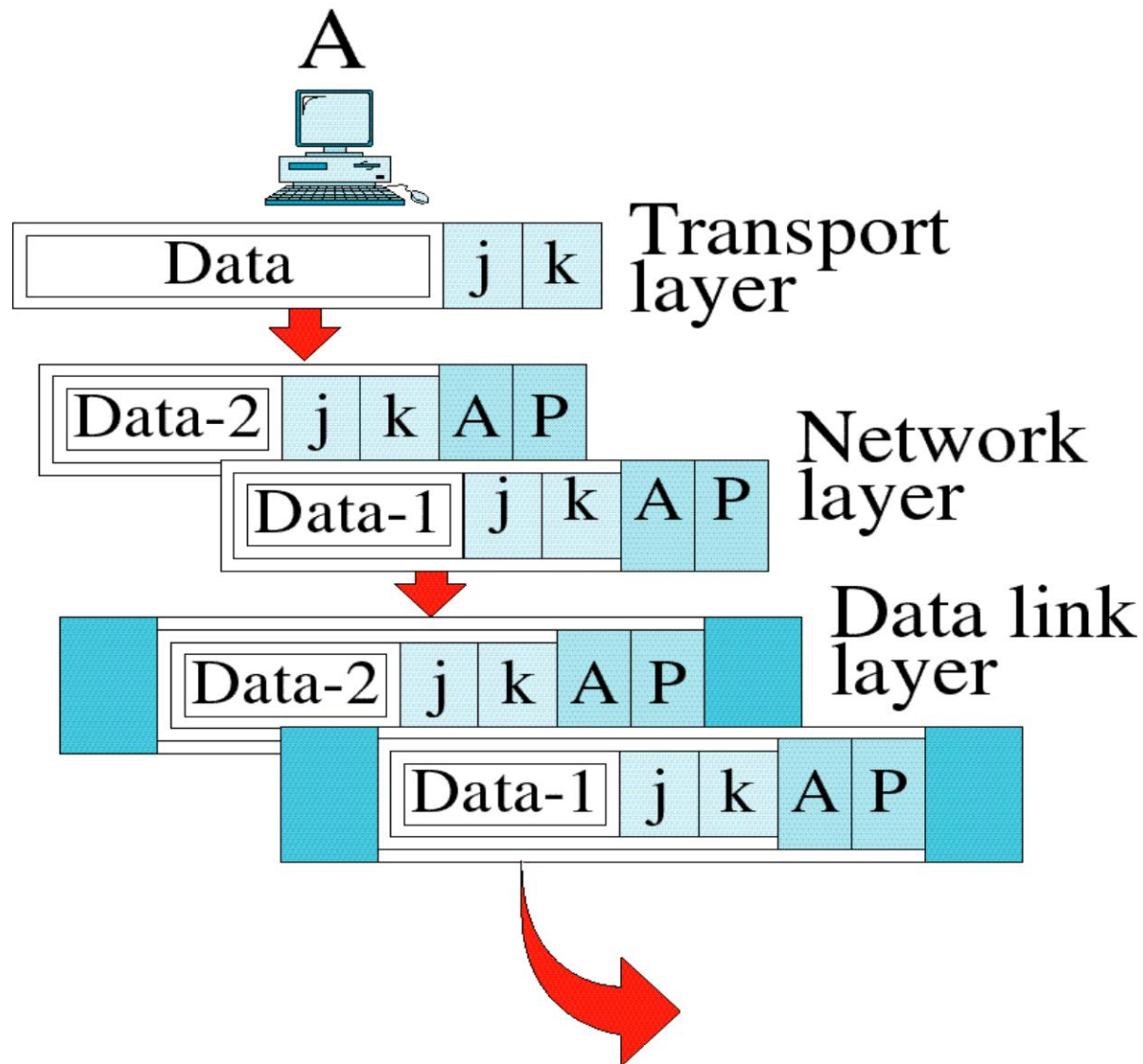

Transport Layer Example

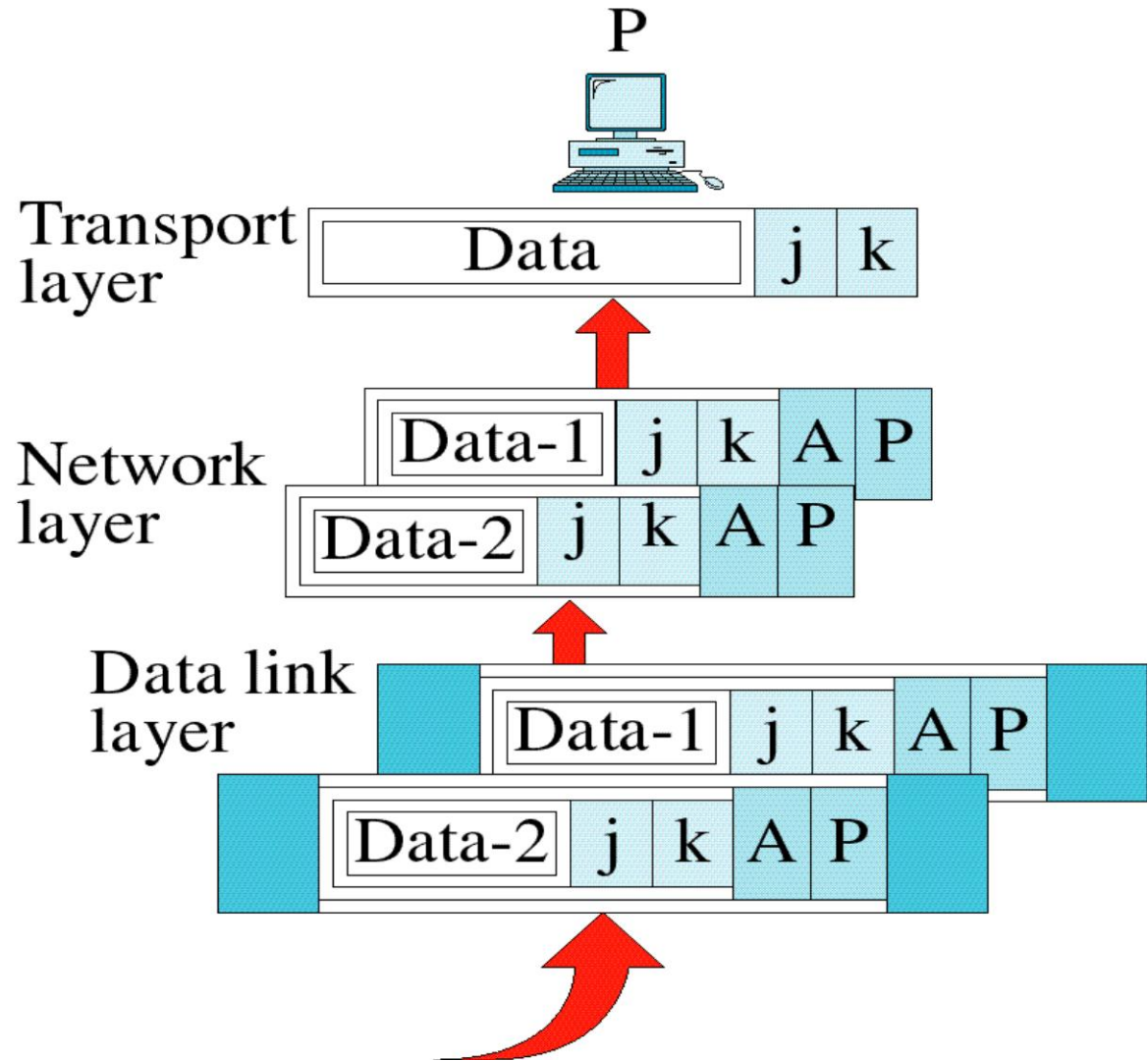

Session Layer

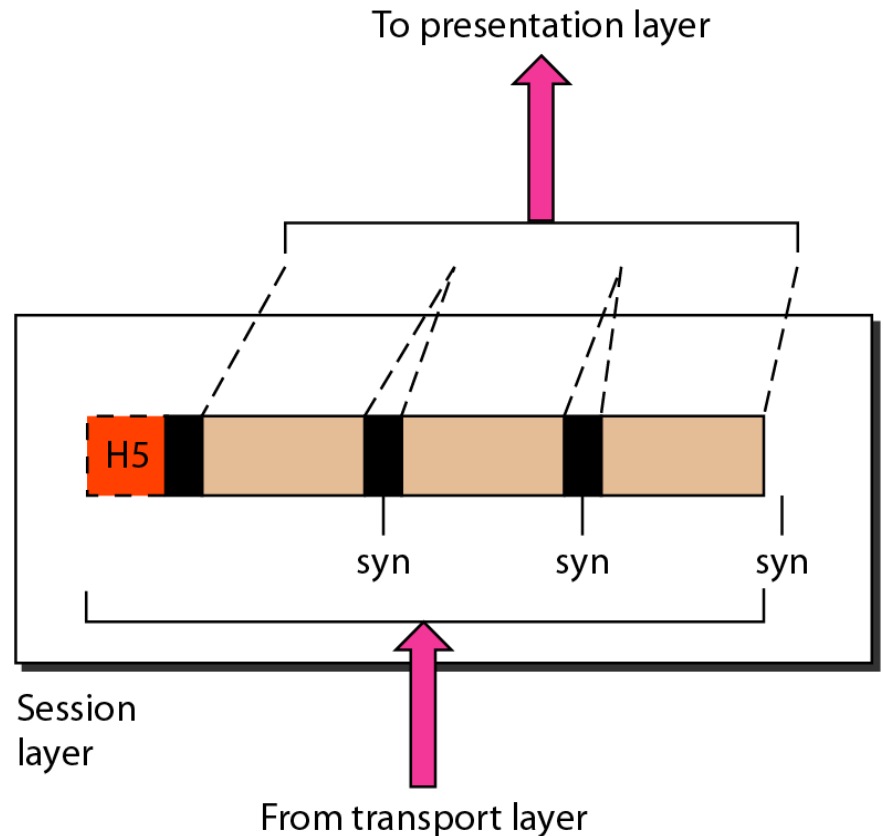
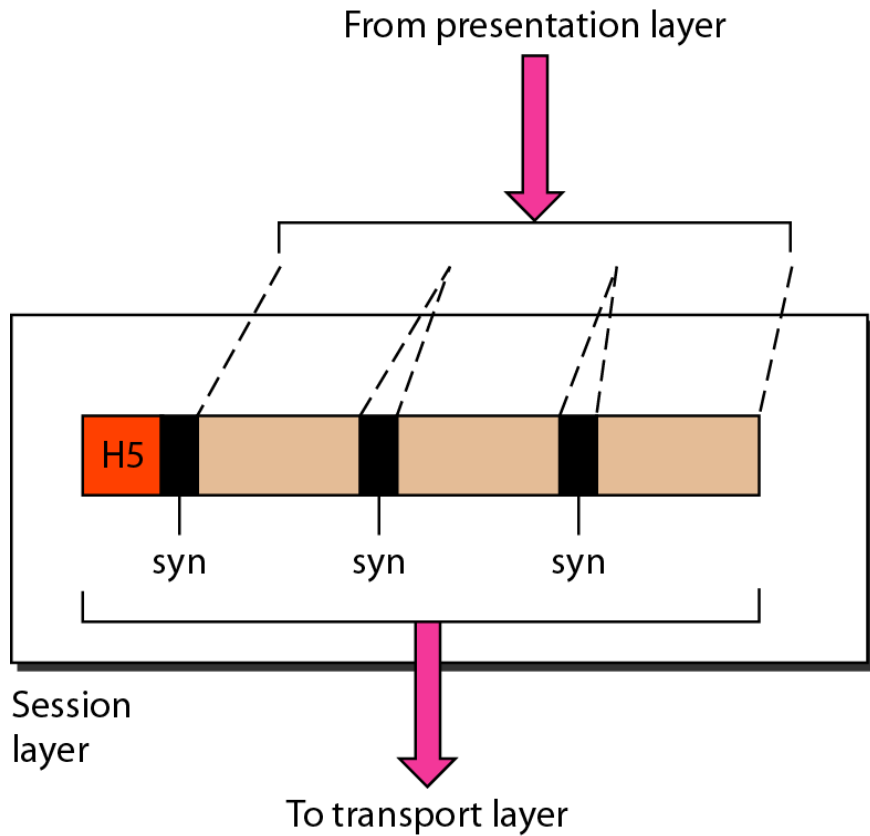

The session layer is responsible for dialog control and synchronization.

Session Layer

Responsibility of Session layer

- ❑ Session layer provides mechanism for controlling the dialogue between the two end systems. It defines how to start, control and end conversations (called sessions) between applications.
- ❑ This layer requests for a logical connection to be established on an end-user's request.
- ❑ Any necessary log-on or password validation is also handled by this layer.
- ❑ Session layer is also responsible for terminating the connection.
- ❑ This layer provides services like dialogue discipline which can be full duplex or half duplex.
- ❑ Session layer can also provide check-pointing mechanism such that if a failure of some sort occurs between checkpoints, all data can be retransmitted from the last checkpoint.

Basic Functions for the Session Layer Protocols

- **Creating a connection** – session/communication session between an APPLICATION in one computer and another APPLICATION in another computer
 - **THREE-WAY-HANDSHAKE**: a method widely used to establish and end connection
 - Sender sends SYN message to request a session to the receiver
 - Receiver replies by sending ACK message to acknowledge the SYN message sent by the sender, and SYN message to request a session to the sender
 - Sender replies by sending ACK message to acknowledge the SYN message sent by the receiver

Basic Functions for the Session Layer Protocols

- **Managing multiple sessions**
 - A computer can establish multiple sessions with several other computers
 - e.g., session 1: exchanging information over the World Wide Web with www.yahoo.com
 - session 2: exchanging information over the World Wide Web with www.google.com
 - session 3: exchanging information over the World Wide Web with www.espn.com
 - Two computers can also establish multiple sessions,
 - e.g., function 1: exchanging information over the World Wide Web;
 - function 2: exchanging information over the FTP;
 - function 3: exchanging information over the email

A computer can establish multiple sessions with several other computers

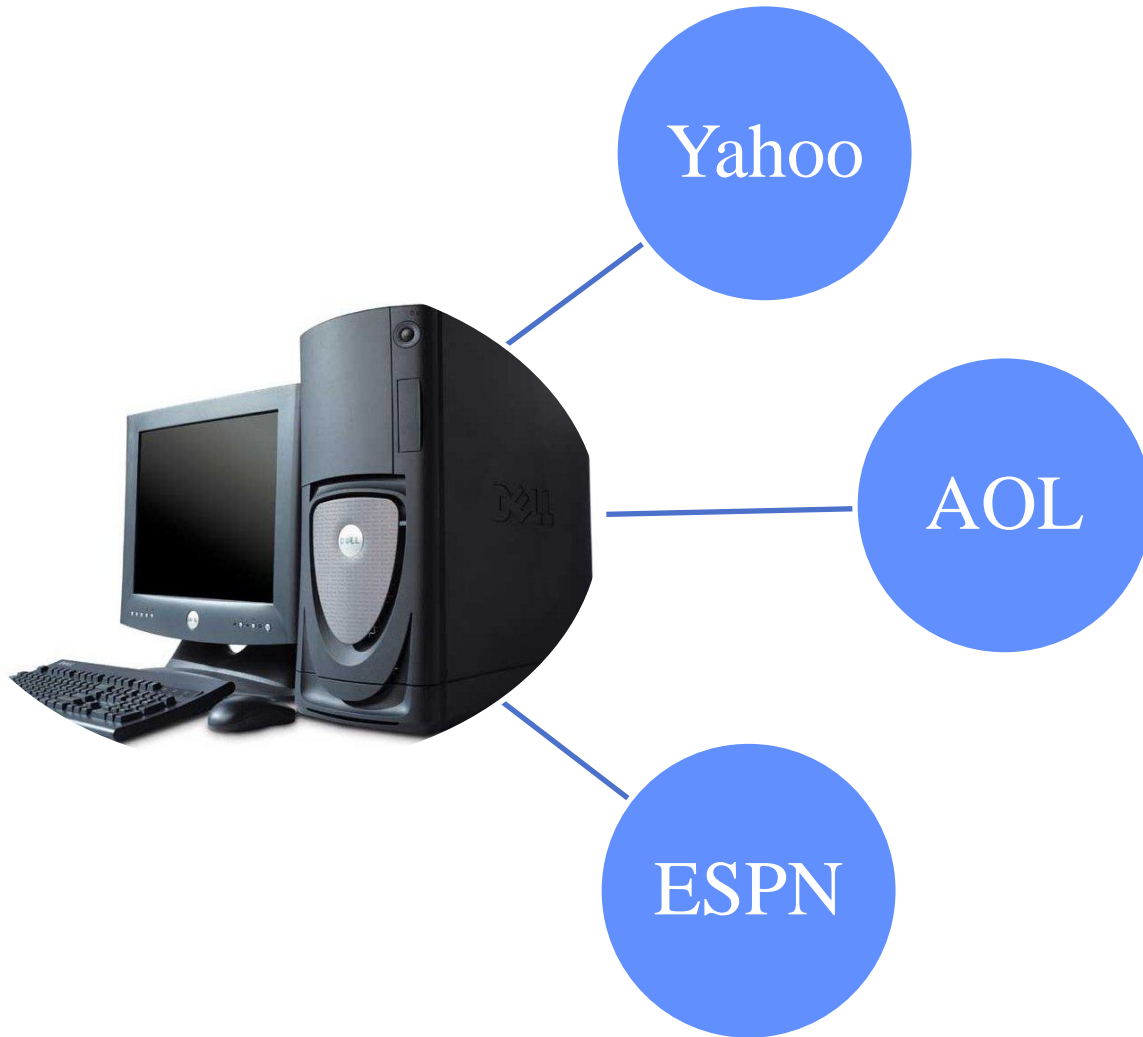

Basic Functions for the Session Layer Protocols

- **Ending a session**
 - THREE-WAY-HANDSHAKE: a method widely used to establish and end connection
 - Sender sends FIN message to close a session to the receiver
 - Receiver replies by sending ACK message to acknowledge the FIN message sent by the sender, and FIN message to close a session to the sender
 - Sender replies by sending ACK message to acknowledge the FIN message sent by the receiver

Presentation Layer

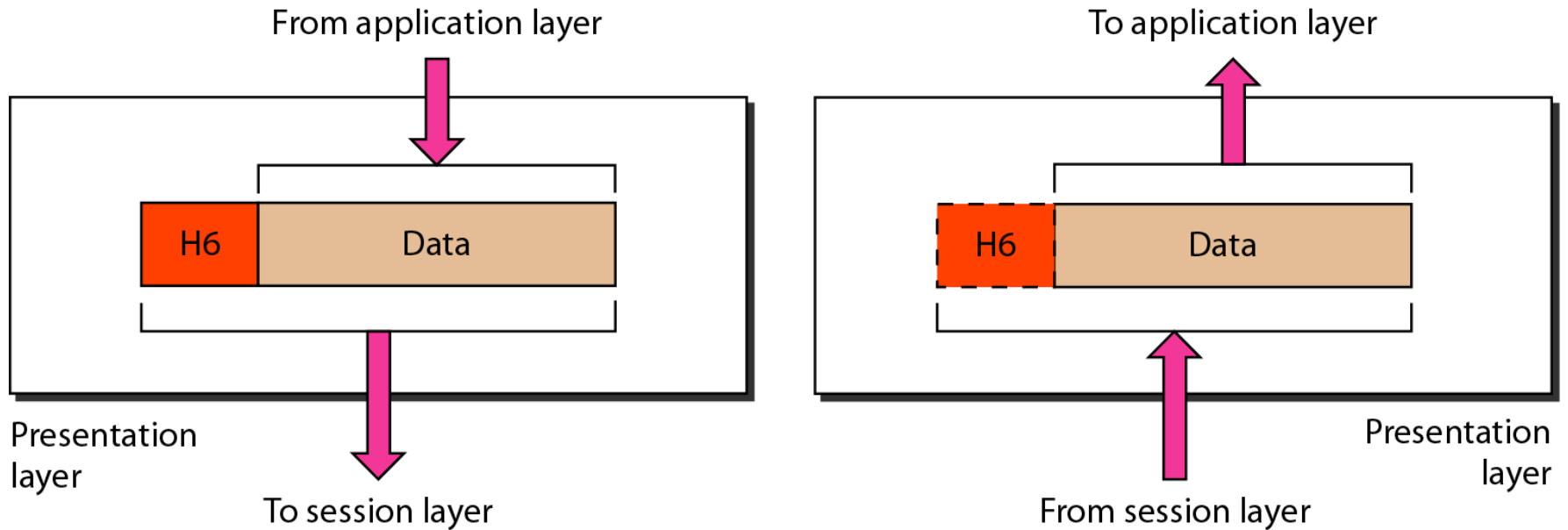

The presentation layer is responsible for translation, compression, and encryption.

Presentation Layer

Responsibility of Presentation layer

- ❑ Presentation layer defines the format in which the data is to be exchanged between the two communicating entities.
- ❑ Also handles data compression and data encryption (cryptography).

Application Layer

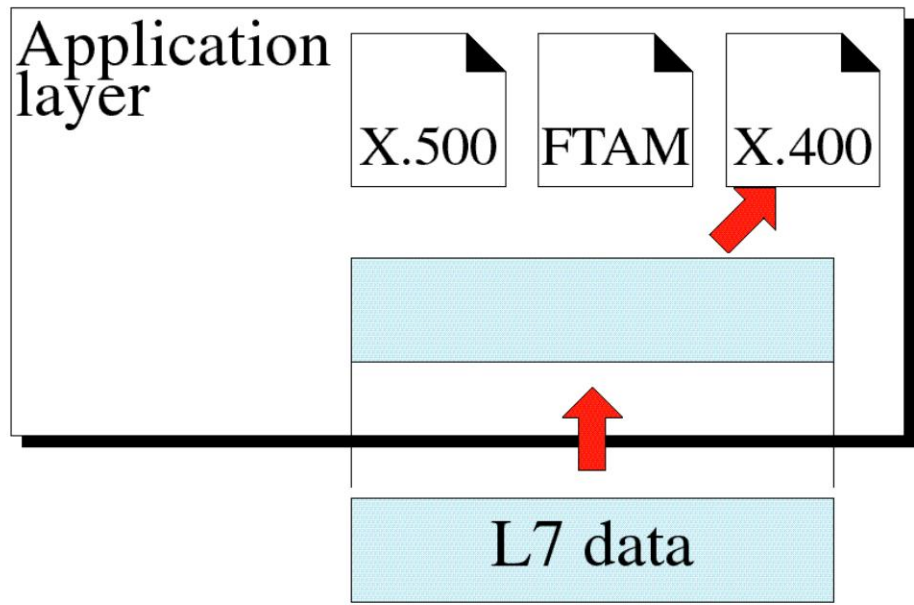
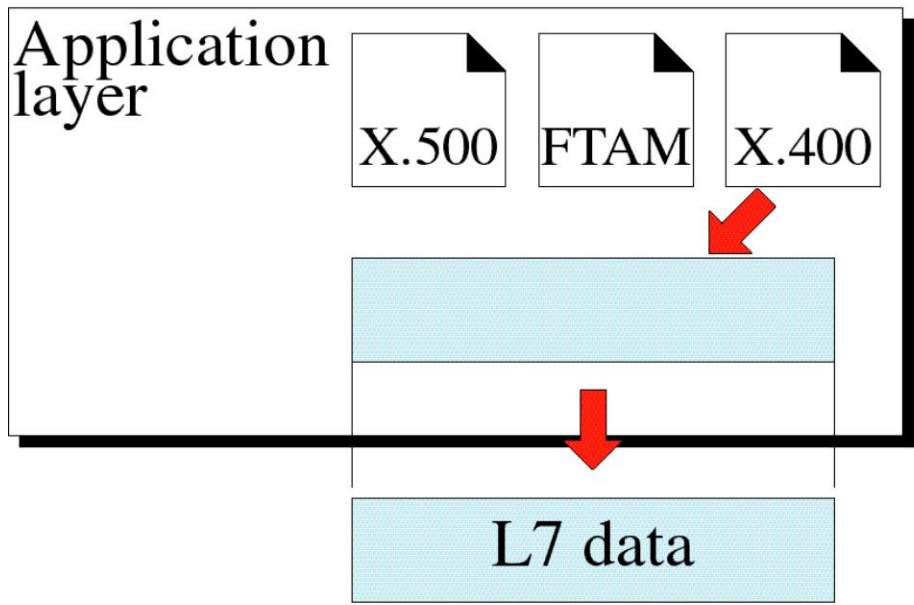

To presentation layer

From presentation layer

The application layer is responsible for providing services to the user.

Application Layer

Responsibility of Application layer

- ❑ Application layer interacts with application programs and is the highest level of OSI model.
- ❑ Application layer contains management functions to support distributed applications.
- ❑ Examples of application layer are applications such as file transfer, electronic mail, remote login etc.

Summary of Layer Functions

